

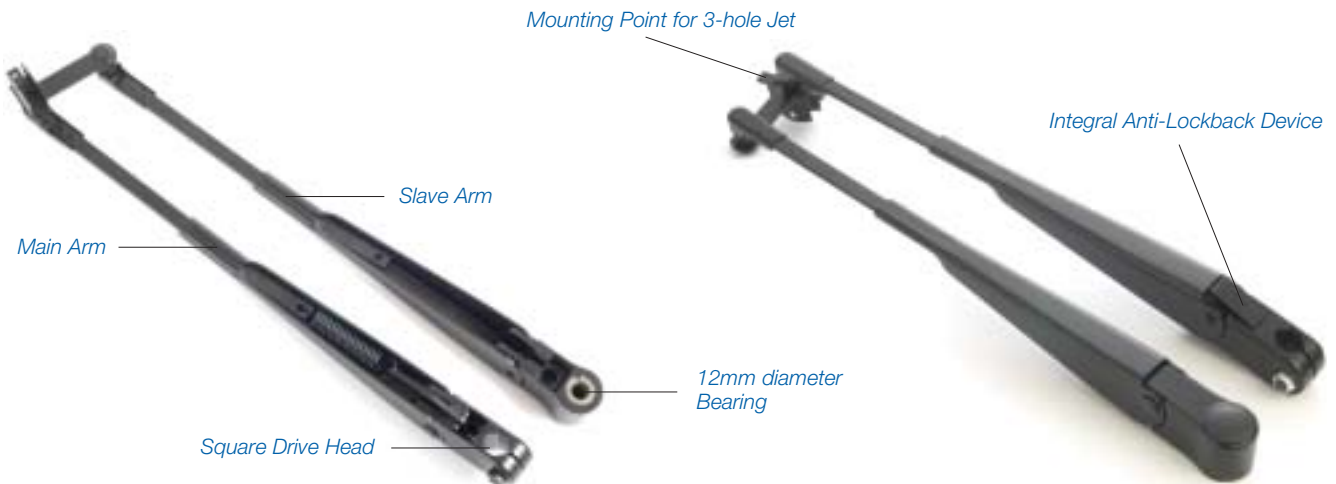

The Matador Company

Square Drive Pantograph Wiper Arm



The square drive range of pantograph wiper arms forms part of a family of new arms produced by Matador which include 12 DIN, 16 DIN and Knurled Driver configurations as related on separate data sheets.

The square drive wiper arm represent a design innovation by Matador that provides the ability to fit the arm to a new style square ended shaft instead of to a tapered spline shaft. It ensures not only that the wiper arm is fitted in the correct 'park' position 'right first time', but is also retained on the shaft by a pinch bolt that engages in a groove around the square thus providing a secondary locking mechanism to prevent axial disengagement. They can be supplied with bridge widths of 44, 50 or 60mm and various blade clip widths including 10.8 or 13.6mm amongst others.



An additional feature with these new types of arms is that they incorporate an integral anti-lift off device that prevents the wiper arm and blade being lifted off the screen during high-speed operation or turbulent air flow conditions. Such anti-lift off devices have previously been fitted as an expensive accessory whereas the integral version is available at no extra cost when compared to the earlier standards of wiper arms.

The wiper arms are finished in a semi-matt black colour process achieved by electro-phoretic paint deposition coupled with a further protective surface that prevents discolouration by ultra-violet light.

Exhaustive testing has been carried out on accelerated life test rigs giving rise to exceptional durability standards that satisfies all known OEM specifications. These tests have further been supported by practical trials on high and medium speed trains over periods of 6-12 months where corresponding results have also been achieved.

THE MATADOR COMPANY LIMITED

UNIT 6 TOP ANGEL, BUCKINGHAM INDUSTRIAL PARK, BUCKINGHAM, MK18 1TH, ENGLAND

FAX: +44 (0)1280 817717 TEL: +44 (0)1280 823824 EMAIL: wipers@matador.co.uk WEBSITE: www.matador.co.uk